

Description

The ExoMare product line is a series of freshwater production units powered by wave energy.

The ExoMare modular product design features mechanical wave energy converters and a reverse osmosis desalination unit.

Installed on the seabed near shore, the wave energy converters supply a steady flow of pressurized seawater to the desalination unit located onshore. ExoMare is a 100% off-grid and fully integrated freshwater system and features nominal production rates between 4 - 20m³/day of quality freshwater.

Designed for easy installation from shore, the ExoMare is ideal for production of water for a wide range of applications, e.g. drinking water, process water or irrigation. The ExoMare product suite also offers a wide range of options including remote monitoring.

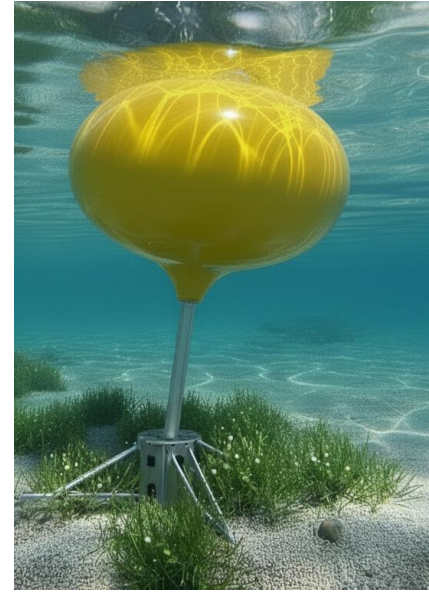

Specifications

Product	ExoMare-16
Capacity, nominal	16 m ³ /day freshwater
Water quality parameters	Sodium < 200mg/L
Max. distance WEC – RO	50m
Compliance	EU CE declaration, ISO 13205

Component	ExoMare-16
Wave Energy converter	WEC-1600
– Quantity	4 units
– Weight	200kg/unit
Reverse osmosis unit	DeSal-16
– Quantity	1 unit
– Membrane vessel type	Fiberglass Reinforced Plastics (FRP)
– Membrane size	4040
– Quantity membranes	4 units
– Pre-filter	5 micron, 95%
– Weight	180kg
– Protection Class	IP65

Description

Designed for manual handling and installation from shore, the assembly and installation of the wave energy converter and reverse osmosis is easy.

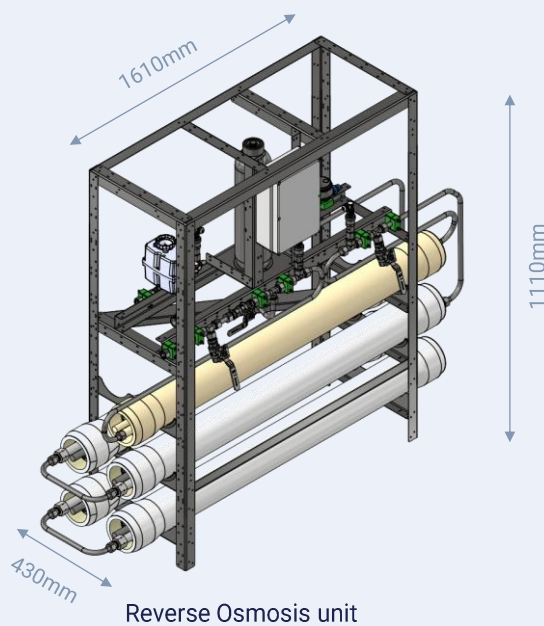

Performance curve

Offering a state-of-the-art capacity factor of 90%, the ExoMare freshwater unit is a reliable source of water 24/7, designed for optimal performance in coastal areas.

